

DWG No.:

79Y61453

NOTE: Information herein is believed by Southwest Microwave, Inc. to be accurate. However, Southwest Microwave assumes no responsibility for any omissions or errors or inaccuracies for its use or for any infringements of patents or other rights of third parties that may result from its use. Data is intended for informational purpose only and does not constitute a contract of sale or any express or implied warranty, including any warranty of merchant ability or fitness for a particular purpose.

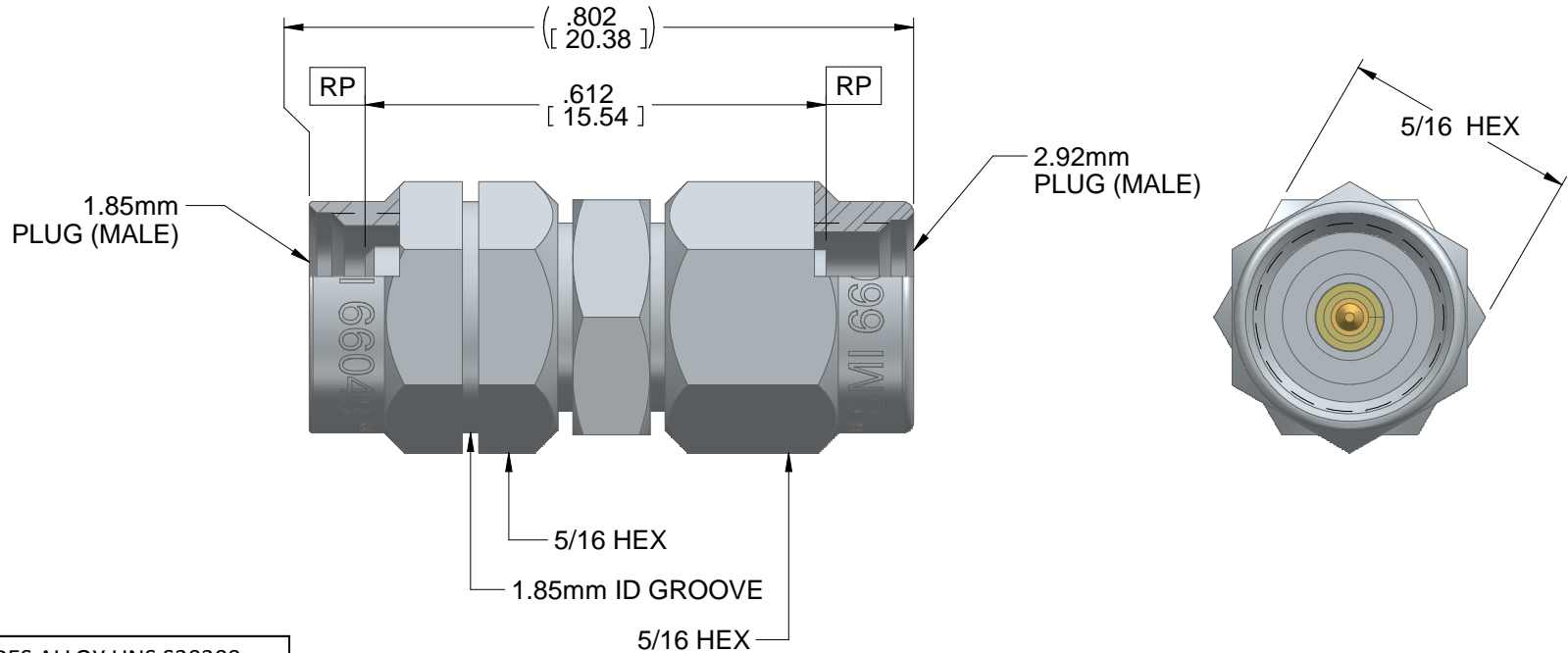

HOUSING AND COUPLING NUT:	STEEL, CRES ALLOY UNS S30300 PER ASTM A582 PASSIVATED PER ASTM A967-99
CONTACT:	BeCu UNS C17300 PER ASTM B196 GOLD PLATE PER MIL-DTL-45204
CAPTURE BEAD:	ULTEM 1000 PER ASTM D5205
RETAINING RING:	BeCu UNS C17200 PER ASTM B194 OR ASTM B197
ITEM	MATERIAL & FINISH

2. SEE 91Y61533 FOR PRODUCT SPECIFICATIONS.

1. ALL DIMENSIONS ARE IN INCHES. ALL ANGLES ARE IN DEGREES.
DIMENSIONS SHOWN IN BRACKETS [XXX] ARE IN MILLIMETERS.

NOTES: UNLESS OTHERWISE SPECIFIED.

REV A	RELEASE	APRVD. PLC	DATE: 5/1/14	TITLE 101840-00SF 2.92mm Plug (Male) to 1.85mm Plug (Male) Adapter		
 <p>SOUTHWEST MICROWAVE</p>		<p>Southwest Microwave, Inc. 9055 South McKerny Street Tempe, Arizona 85284-2946 Telephone (480) 783-0201 Fax (480) 783-0360</p>		DRN BY: EAG	DATE: 04/30/14	DWG. NO.
				SHEET: 1 OF 1		79Y61453