

NOTE: Information herein is believed by Southwest Microwave, Inc. to be accurate. However, Southwest Microwave assumes no responsibility for any omissions or errors or inaccuracies for its use or for any infringements of patents or other rights of third parties that may result from its use. Data is intended for informational purpose only and does not constitute a contract of sale or any express or implied warranty, including any warranty of merchant ability or fitness for a particular purpose.

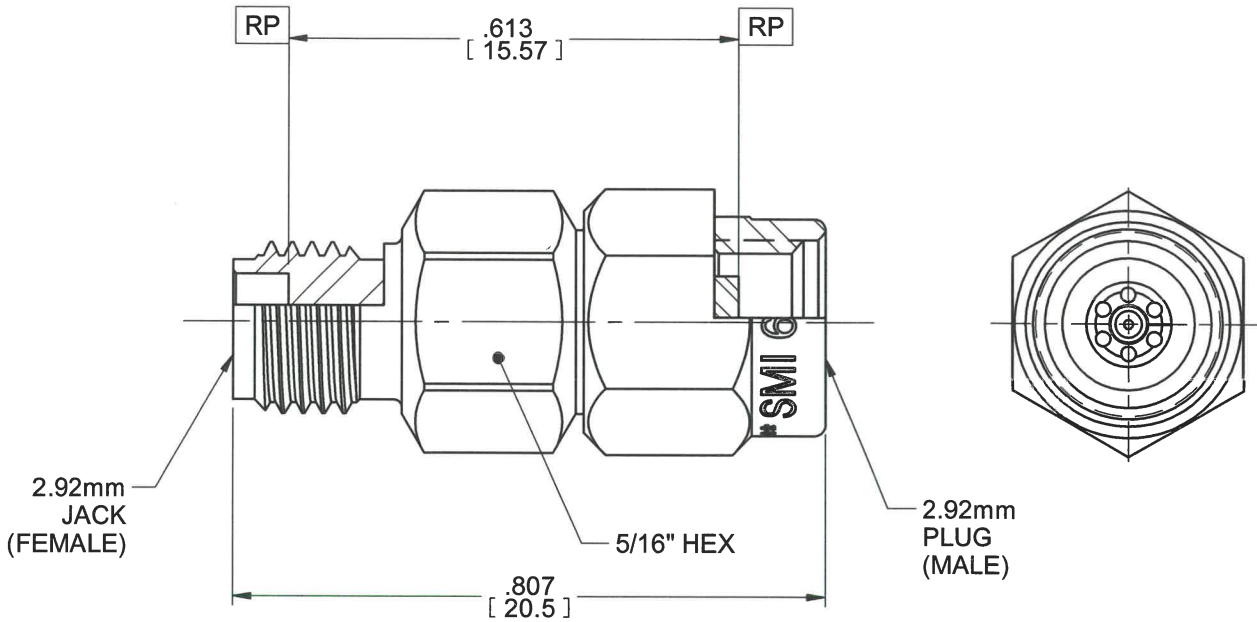

CONTACT SPECIFICATION	91K52111
SPECIFICATIONS	91K52092
INTERFACE 2.92mm PLUG	91K52018
INTERFACE 2.92mm JACK	91K52019
SPECIFICATION GROUP	DRAWING NO.

HOUSING:	STEEL, CRES ALLOY UNS-30300 PER ASTM A582
COUPLING NUT:	STEEL, CRES ALLOY UNS-30300 PER ASTM A582
RETAINING RING:	BeCu PER ASTM B194/197
CONTACT:	BeCu UNS-C17300 PER ASTM B196/197 GOLD PLATE PER ASTM B488
DIELECTRIC:	VIRGIN PTFE FLUOROCARBON PER ASTM D1710, TYPE 1 GRADE 1, CLASS B
CAPTURE BEAD:	ULTEM 1000 PER ASTM D5205
GASKET:	SILICON RUBBER ZZ-R-765 CLASS II B, GRADE 65-75
ITEM	MATERIAL & FINISH

2. INTERFACE I.A.W. MIL-STD-348

1. ALL DIMENSIONS ARE IN INCHES. ALL ANGLES ARE IN DEGREES. DIMENSIONS SHOWN IN BRACKETS [XXX] ARE IN MILLIMETERS.

NOTES: UNLESS OTHERWISE SPECIFIED.

REV D	ECN: 9674	REV BY: ELC	DATE: 11/7/17	APRVD: JW	DATE: 11/8/17	TITLE 1030-00SF 2.92mm PLUG TO JACK ADAPTER			
 <p>Southwest Microwave, Inc. 9055 South McKemy Street Tempe, Arizona 85284-2946 Telephone (480) 783-0201 Fax (480) 783-0360</p>						DRN BY: DK	DATE: 11/22/94	MODEL NO. 1030-00SF	REV. D
						SCALE: 4:1			
						SHEET: 1 OF 1	DWG. NO. 79K53662		