

NOTE: Information herein is believed by Southwest Microwave, Inc. to be accurate. However, Southwest Microwave assumes no responsibility for any omissions or errors or inaccuracies for its use or for any infringements of patents or other rights of third parties that may result from its use. Data is intended for informational purpose only and does not constitute a contract of sale or any express or implied warranty, including any warranty of merchant ability or fitness for a particular purpose.

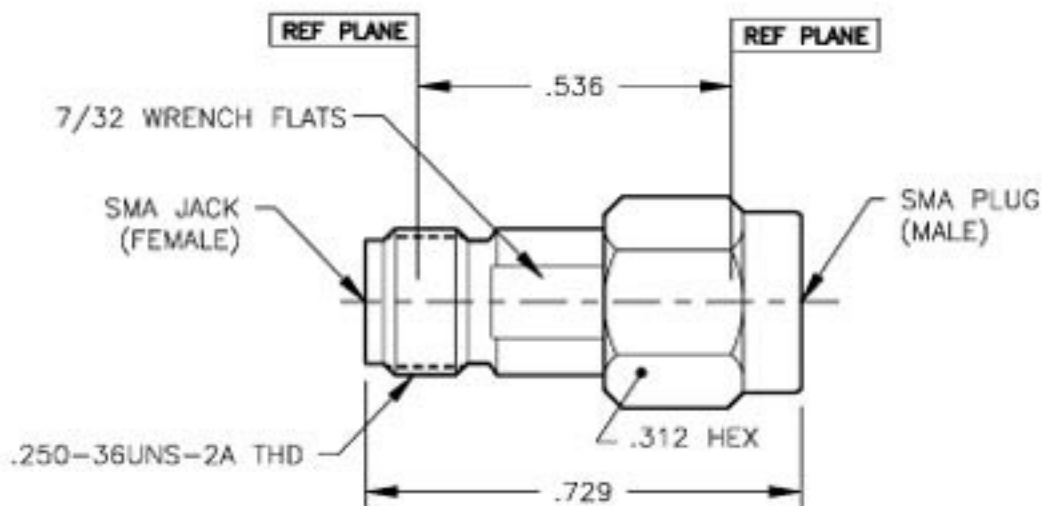

HOUSING: COUPLING NUT:	STEEL, CRES ALLOY UNS-S30300 PER ASTM-A582. PASSIVATE PER QQ-P-35.
CONTACT:	BeCu UNS-C17300 PER ASTM-B-196/197 GOLD PLATE PER MIL-G-45204
DIELECTRIC INSULATOR:	VIRGIN TFE FLUOROCARBON PER ASTM-D-1710 AND ASTM-D-1457
BEAD RING:	ULTEM 1000 PER ASTM-D-5205
RETAINING RING:	BeCu UNS-C17300 PER ASTM-B-196/197
GASKET:	SILICONE RUBBER PER ZZ-R-765
<b>MATERIAL &amp; FINISH</b>	

CONTACT GAGING SPEC.	91B52100
SPECIFICATIONS	91B54906
INTERFACE PLUG	91B52002
INTERFACE JACK	91B52003
<b>SPECIFICATION GROUP</b>	<b>DRAWING NO.</b>

2. INTERFACE IN ACCORDANCE WITH MIL-STD-348.

1. ALL DIMENSIONS ARE IN INCHES, ALL ANGLES ARE IN DEGREES.

NOTES: UNLESS OTHERWISE SPECIFIED

REV A	RELEASE	DATE: 1/2/04	APRVD. BC	DATE: 1/2/04
----------	---------	-----------------	--------------	-----------------

TITLE  
**MODEL 230-506SF  
EXT PWR SMA  
JACK TO PLUG ADAPTER**



Southwest Microwave, Inc.  
9055 South McKerry Street  
Tempe, Arizona 85284-2946  
Telephone (480) 783-0201  
Fax (480) 783-0360

DRN BY: EJO	DATE: 4/04	DWG. NO.
SCALE: 3:1		
SHEET: 1 OF 1		

**79B58261**

REV.  
**A**