

CONFIDENTIAL  
 PROPRIETARY INFORMATION OF  
 SOUTHWEST MICROWAVE, INC.  
 THIS DOCUMENT SHALL NOT BE  
 REPRODUCED IN ANY MANNER

NOTE: Information herein is believed by Southwest Microwave, Inc. to be accurate. However, Southwest Microwave assumes no responsibility for any omissions or errors or inaccuracies for its use or for any infringements of patents or other rights of third parties that may result from its use. Data is intended for informational purpose only and does not constitute a contract of sale or any express or implied warranty, including any warranty of merchant ability or fitness for a particular purpose.

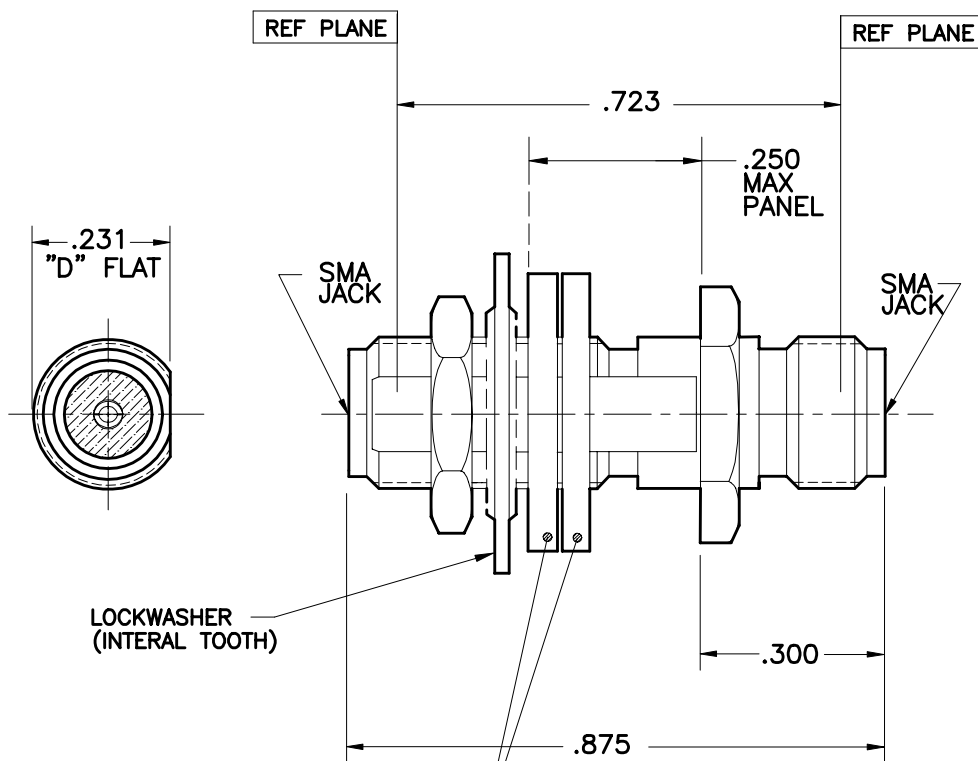

TWO(2) FLAT WASHERS, .062 WIDE  
 FOR PANELS .063-.140 THK, USE TWO(2) FLAT WASHERS  
 FOR PANELS .140-.215 THK, USE ONE(1) FLAT WASHER  
 FOR PANELS .215-.250 THK, USE ZERO(0) FLAT WASHERS

HOUSING:	STEEL, CRES ALLOY UNS-S30300 PER ASTM-A582. PASSIVATE PER QQ-P-35.
CONTACT:	BeCu UNS-C17300 PER ASTM-B-196/197 GOLD PLATE PER MIL-G-45204
DIELECTRIC INSULATOR:	VIRGIN TFE FLUOROCARBON PER ASTM-D-1710 AND ASTM-D-1457
BEAD RING:	ULTEM 1000 PER ASTM-D-5205
<b>MATERIAL &amp; FINISH</b>	

CONTACT GAGING SPEC.	91B52100
SPECIFICATIONS	91B54908
INTERFACE	91B52003
<b>SPECIFICATION GROUP</b>	<b>DRAWING NO.</b>

2. INTERFACE IN ACCORDANCE WITH MIL-STD-348.

1. ALL DIMENSIONS ARE IN INCHES, ALL ANGLES ARE IN DEGREES.

NOTES: UNLESS OTHERWISE SPECIFIED

REV A	RELEASE	DATE: 4/12/04	APRVD. R.BOAK	DATE: 4/12/04	TITLE <b>MODEL 232-510SF EXT PWR SMA JACK TO JACK BULKHEAD ADAPTER</b>			
 Southwest Microwave, Inc. 9055 South McKemy Street Tempe, Arizona 85284-2946 Telephone (480) 783-0201 Fax (480) 783-0360					DRN BY: EJO	DATE: 4/04	DWG. NO.	REV. A
					SCALE: 3:1		<b>79B58267</b>	
					SHEET: 1 OF 1			

O.L.-A--303 REV B