

MODEL No.:

2432-01SF

NOTE: Information herein is believed by Southwest Microwave, Inc. to be accurate. However, Southwest Microwave assumes no responsibility for any omissions or errors or inaccuracies for its use or for any infringements of patents or other rights of third parties that may result from its use. Data is intended for informational purpose only and does not constitute a contract of sale or any express or implied warranty, including any warranty of merchant ability or fitness for a particular purpose.

DOCUMENT CONTROL
FEB 20 2019

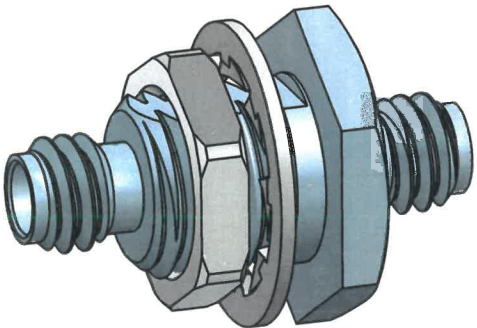
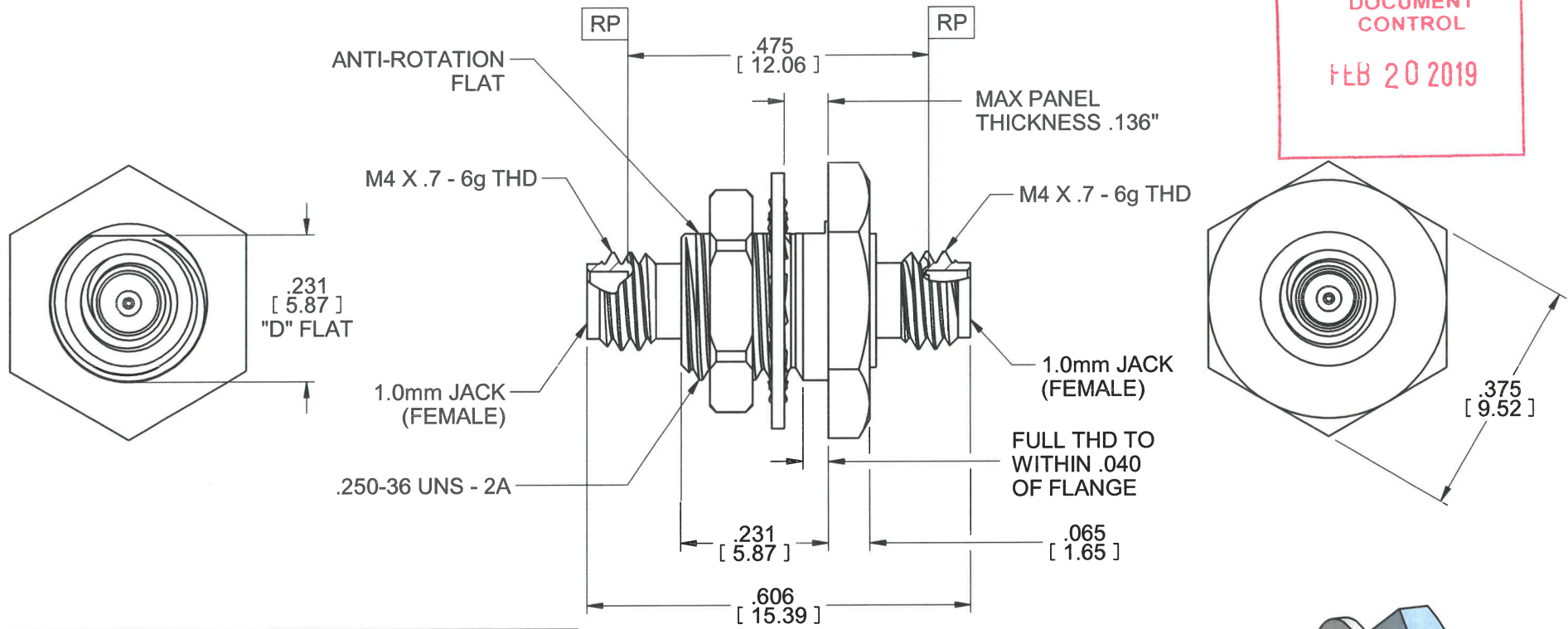

HOUSING:	STEEL, CRES ALLOY UNS-30300 PER ASTM A582 PASSIVATED PER ASTM A967-99
CONTACT:	BeCu UNS-C17300 PER ASTM B196 GOLD PLATE PER MIL-DTL-45204
CAPTURE BEAD:	ULTEM 1000 PER ASTM D5205
ITEM	MATERIAL & FINISH

SPECIFICATION	91W61851
INTERFACE	91W68459
SPECIFICATION GROUP	DRAWING NO.

1. ALL DIMENSIONS ARE IN INCHES. ALL ANGLES ARE IN DEGREES. DIMENSIONS SHOWN IN BRACKETS [XXX] ARE IN MILLIMETERS.

NOTES: UNLESS OTHERWISE SPECIFIED.

REV X0	PROTOTYPE RELEASE	APRVD. D.E.	DATE: 2/20/19
--------	-------------------	-------------	---------------



Southwest Microwave, Inc.
9055 South McKerny Street
Tempe, Arizona 85284-2946
Telephone (480) 783-0201
Fax (480) 783-0360

TITLE		MODEL 2432-01SF	
		1.0mm J TO 1.0mm J BLKHD ADP	
DRN BY: JAC	DATE: 01/23/19	DWG. NO.	REV. X0
SCALE: 4:1			
SHEET: 1 OF 1		79W68821	

1.0 mm JACK to 1.0 mm JACK (110 GHz) ADAPTER TEST DATA

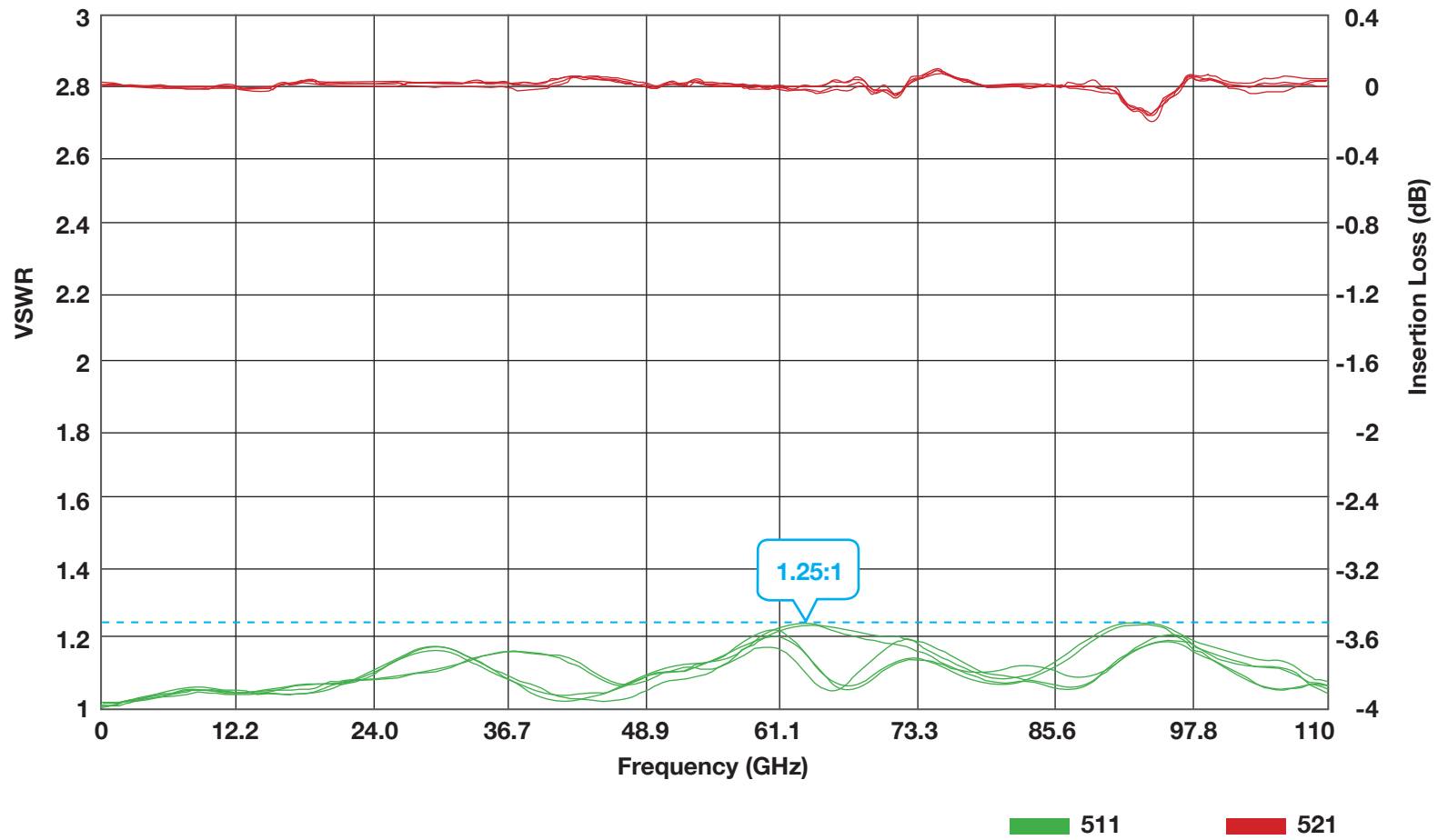

*Calibration standard has greater attenuation than the adapter, causing gain. Insertion loss is offset by 2dB.
Data illustrates five different adapters delivering reliable performance.*