

NOTE: Information herein is believed by Southwest Microwave, Inc. to be accurate. However, Southwest Microwave assumes no responsibility for any omissions or errors or inaccuracies for its use or for any infringements of patents or other rights of third parties that may result from its use. Data is intended for informational purpose only and does not constitute a contract of sale or any express or implied warranty, including any warranty of merchant ability or fitness for a particular purpose.

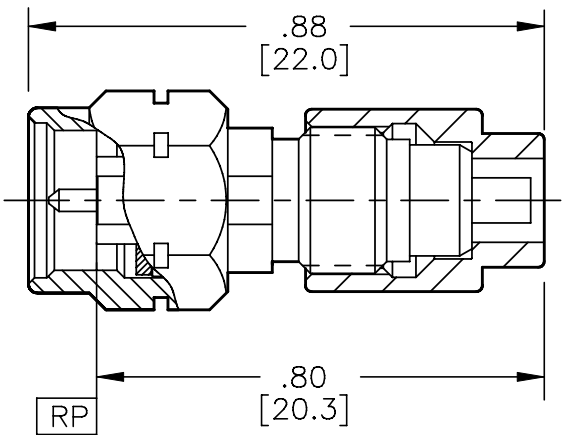
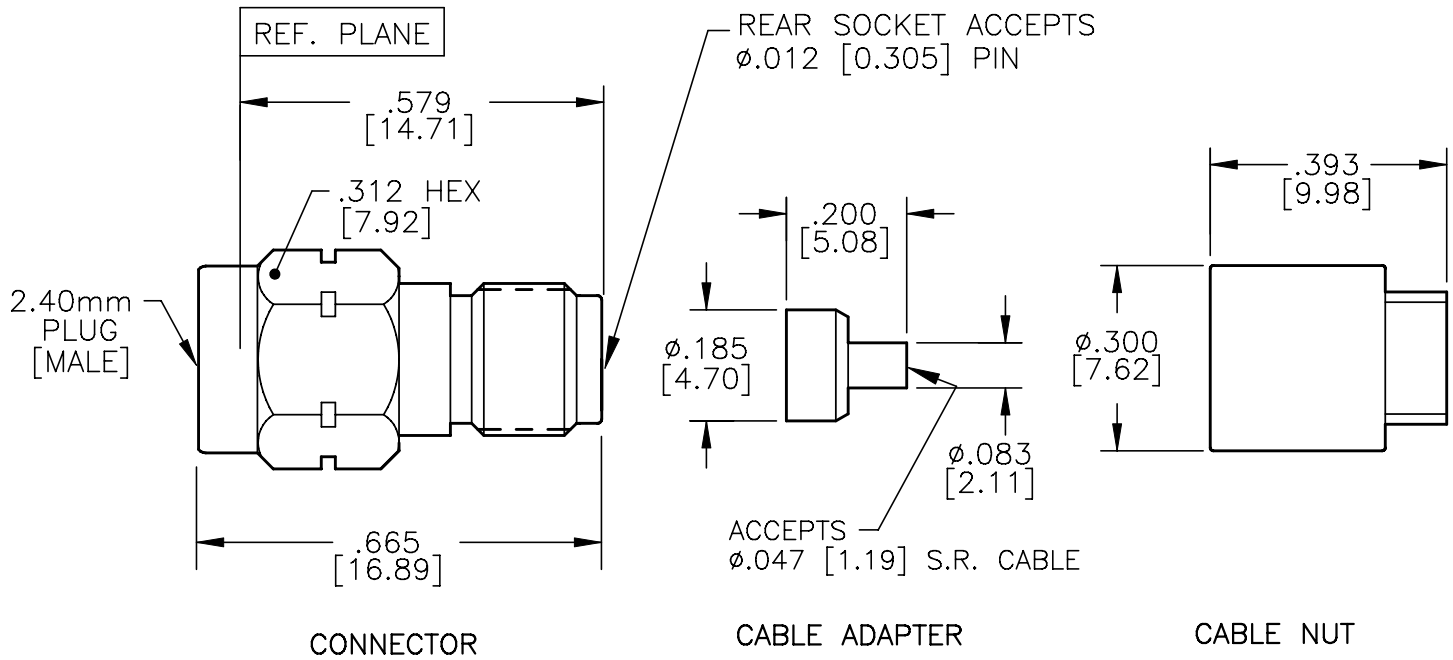

|                           |  |
|---------------------------|--|
| HOUSING:<br>COUPLING NUT: | STEEL, CRES ALLOY UNS-S30300<br>PER ASTM-A582.<br>PASSIVATE PER ASTM-A967-99       |
| CONTACT:                  | BeCu<br>UNS-C17300 PER ASTM-B-196/197<br>GOLD PLATE PER MIL-G-45204                |
| BEAD RING:                | 1) ULTEM 1000 PER ASTM-D-5205<br>2) KEL-F PER MIL-P-46036                          |
| RETAINING RING:           | BeCu<br>UNS-C17300 PER ASTM-B-196/197  |
| GASKET:                   | SILICONE RUBBER PER ZZ-R-765   |
| CABLE ADAPTER:            | BRASS, COPPER ALLOY UNS#C36000<br>PER ASTM-B-16/249.<br>GOLD PLATE PER MIL-G-45204 |
| CABLE NUT:                | STEEL, CRES ALLOY UNS-S30300<br>PER ASTM-A582.<br>PASSIVATE PER ASTM-A967-99       |
| ITEM                      | MATERIAL & FINISH  |

2. INTERFACE I.A.W. MIL-STD-348

1. ALL DIMENSIONS ARE IN INCHES, ALL ANGLES ARE IN DEGREES. DIMENSIONS SHOWN IN BRACKETS [XXX] ARE MILLIMETERS.

TOLERANCES ARE BASED UPON DIMENSIONS IN INCHES. METRIC DIMENSIONS ARE FOR "REFERENCE ONLY".

NOTES: UNLESS OTHERWISE SPECIFIED

|                      |             |
|----------------------|-------------|
| CABLE ASSY. INSTR.   | 91S59287    |
| CONTACT GAGING SPEC. | 91B52104    |
| SPECIFICATIONS       | 91P56084    |
| INTERFACE            | 91P53660    |
| SPECIFICATION GROUP  | DRAWING NO. |

|          |              |             |                  |               |                 |
|----------|--------------|-------------|------------------|---------------|-----------------|
| REV<br>B | ECN:<br>8358 | INIT:<br>SS | DATE:<br>7/18/06 | APRVD.<br>EJO | DATE:<br>8/2/06 |
|----------|--------------|-------------|------------------|---------------|-----------------|

|  |  |                      |               |                        |           |
|--|--|----------------------|---------------|------------------------|-----------|
| TITLE<br>2.40mm P CABLE CONNECTOR<br>TO ACCEPT .047 SEMI-RIGID CABLE |  | DRN BY:<br>EJO       | DATE:<br>2/00 | MODEL NO.<br>1401-01SF | REV.<br>B |
| SCALE: 3:1   |  | DWG. NO.<br>79P56254 |               |                        |           |
| SHEET: 1 OF 1  |  |                      |               |                        |           |



**Southwest Microwave, Inc.**  
9055 South McKemy Street  
Tempe, Arizona 85284-2946  
Telephone (480) 783-0201  
Fax (480) 783-0360

O.L.-A-303 REV0