

DWG No.:

79W61585

NOTE: Information herein is believed by Southwest Microwave, Inc. to be accurate. However, Southwest Microwave assumes no responsibility for any omissions or errors or inaccuracies for its use or for any infringements of patents or other rights of third parties that may result from its use. Data is intended for informational purpose only and does not constitute a contract of sale or any express or implied warranty, including any warranty of merchant ability or fitness for a particular purpose.

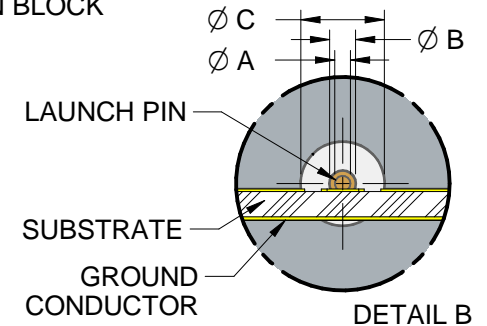
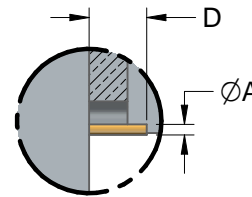
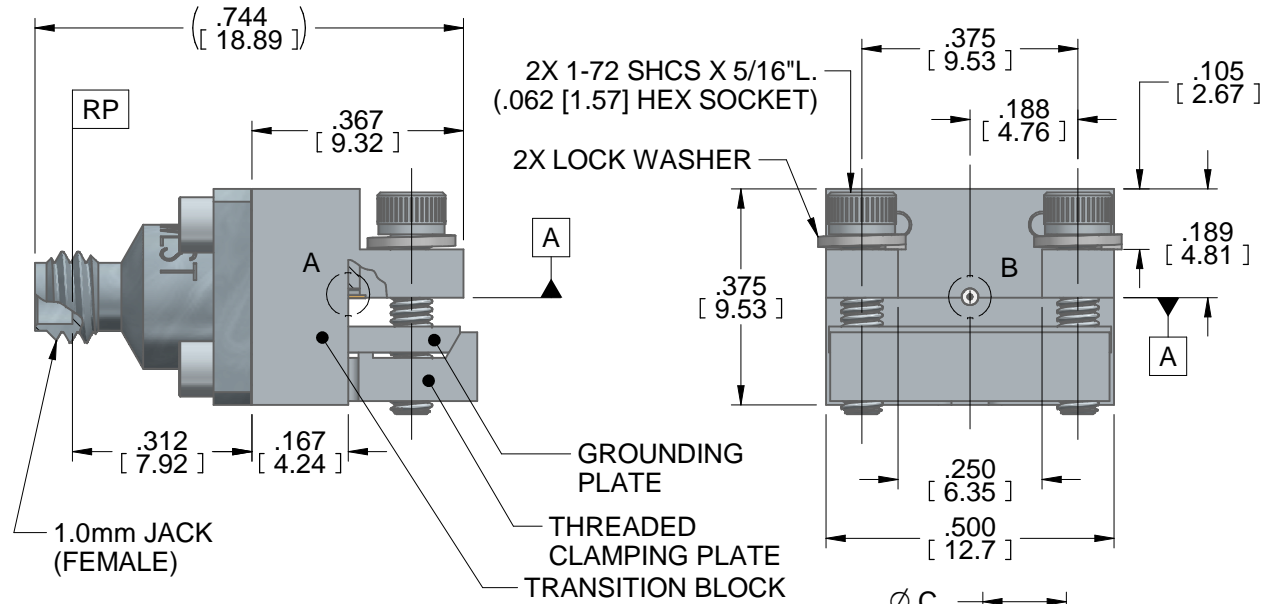
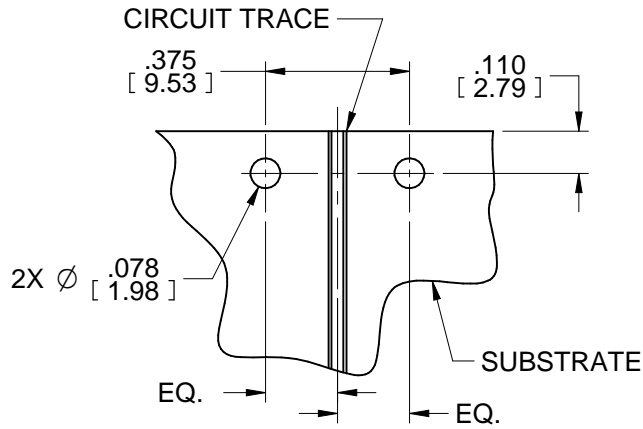

Model	$\varnothing A$	$\varnothing B$	$\varnothing C$	D
2492-04A-6	.005	.009	.0290	.030

HOUSING:	STEEL, CRES ALLOY UNS 30300 PER ASTM A582 PASSIVATED PER ASTM A967-99
CONTACT:	BeCu UNS C17300 PER ASTM B196 GOLD PLATE PER MIL-DTL-45204
CAPTURE BEAD:	ULTEM 1000 PER ASTM D5205
ITEM	MATERIAL & FINISH
<b>1.0mm CONNECTOR</b>	

TRANSITION BLOCK, GROUNDING PLATE, THREADED CLAMPING PLATE:	C360 BRASS ALLOY UNS C36000 PER ASTM B16. NICKEL PLATE PER AMS 2404B
LAUNCH PIN:	BeCu UNS C17300 PER ASTM B196 GOLD PLATE PER MIL-DTL-45204
TRANSITION BLOCK DIELECTRIC:	VIRGIN PTFE FLUOROCARBON PER ASTM D1710, TYPE 1 GRADE 1, CLASS B
ITEM	MATERIAL & FINISH
<b>TRANSITION BLOCK</b>	

1. ALL DIMENSIONS ARE IN INCHES. ALL ANGLES ARE IN DEGREES. DIMENSIONS SHOWN IN BRACKETS [XXX] ARE IN MILLIMETERS.

NOTES: UNLESS OTHERWISE SPECIFIED.

REV A	RELEASE	APRVD. PLC	DATE: 5/23/14	TITLE <b>1.0mm JACK (FEMALE) END LAUNCH CONNECTOR LOW PROFILE</b>			
 Southwest Microwave, Inc. 9055 South McKemy Street Tempe, Arizona 85284-2946 Telephone (480) 783-0201 Fax (480) 783-0360				DRN BY: DE	DATE: 05/20/14	DWG. NO. <b>79W61585</b>	REV. <b>A</b>
				SHEET: 1 OF 1			