

NOTE: Information herein is believed by Southwest Microwave, Inc. to be accurate. However, Southwest Microwave assumes no responsibility for any omissions or errors or inaccuracies for its use or for any infringements of patents or other rights of third parties that may result from its use. Data is intended for informational purpose only and does not constitute a contract of sale or any express or implied warranty, including any warranty of merchant ability or fitness for a particular purpose.

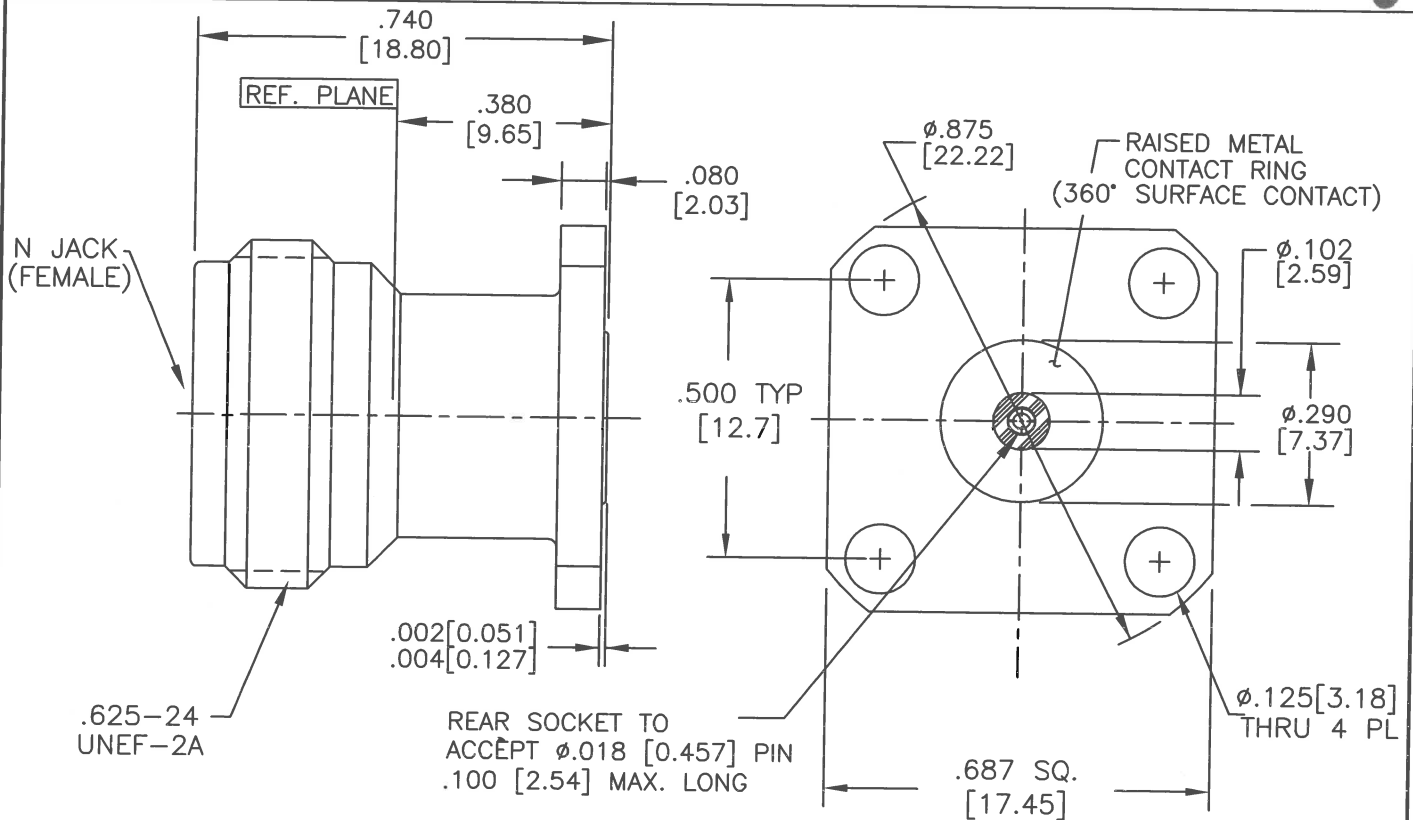

HOUSING AND RAISED METAL CONTACT RING:	STEEL, CRES ALLOY UNS-S30300 PER ASTM-A582. PASSIVATE PER ASTM-A967-99
CONTACT:	BeCu UNS-C17300 PER ASTM-B-196/197 GOLD PLATE PER MIL-G-45204
DIELECTRIC:	VIRGIN TFE FLUOROCARBON PER ASTM-D-1710 AND ASTM-D-1457
BEAD RING:	ULTEM 1000 PER ASTM-D-5205
MATERIAL & FINISH	

2. INTERFACE I.A.W. THE REQUIREMENTS OF MIL-STD-348.
1. ALL DIMENSIONS ARE IN INCHES, ALL ANGLES ARE IN DEGREES. METRIC DIMENSIONS ARE SHOWN IN BRACKETS [MILLIMETERS].

NOTES: UNLESS OTHERWISE SPECIFIED

CONTACT GAGING SPEC. N SOCKET	91C54030
CONTACT GAGING SPEC. .018 SOCKET	91B52102
SPECIFICATIONS	91C58452
SPECIFICATION GROUP	DRAWING NO.

REV B	ECN: 8785	INIT: EAG	DATE: 5/13/09	APRVD: BR	DATE: 5/15/09
-------	-----------	-----------	---------------	-----------	---------------



Southwest Microwave, Inc.
 9055 South McKemy Street
 Tempe, Arizona 85284-2946
 Telephone (480) 783-0201
 Fax (480) 783-0360

TITLE ULTEM CAPTURE N JACK 11/16SQ FLANGE TO ACCEPT (.018) DIA. PIN			
DRN BY: SS	DATE: 9/06	MODEL NO. 312-06SF	REV. B
SCALE: 3:1	DWG. NO. 79C58699		
SHEET: 1 OF 1			

O.L.-A-303 REV B