

Part No:

HWLPT12-03-ER



WR-12 Low Power Millimeter Waveguide Termination, 0.3 W Average - 60 GHz to 90 GHz



Electrical

- Frequency Range 60 - 90 GHz
- VSWR 1.05:1 Max
- Average Power 0.3 W
- Waveguide UG-387/U
- Length 1.5 in

Material

- Waveguide Material Copper
- Flange Material Gold Plated Brass

HWLPT12-03-ER is a general purpose WR-12 millimeter waveguide termination from HASCO. This waveguide termination will operate from 60 to 90 GHz. A Millimeter Waveguide Termination is a passive RF device specifically designed to prevent RF signals from reflecting back from open-ended or unused waveguide ports. Millimeter Waveguide Terminations dissipate RF energy by producing heat energy. HASCO offers a series of waveguide terminations covering the waveguide sizes WR-10, WR-12, WR-15, WR-19, WR-22, WR-28, WR-34, WR-42, WR-51, WR-62, WR-75, WR-90 and WR-112.

The HWLPT12-03-ER is RoHS compliant.



HASCO stocks an extensive selection of RF and Microwave between-series, in-series, right angle and low PIM adapters.

WR-12 Low Power Millimeter Waveguide Termination | 60 - 90 GHz | Outline Drawing

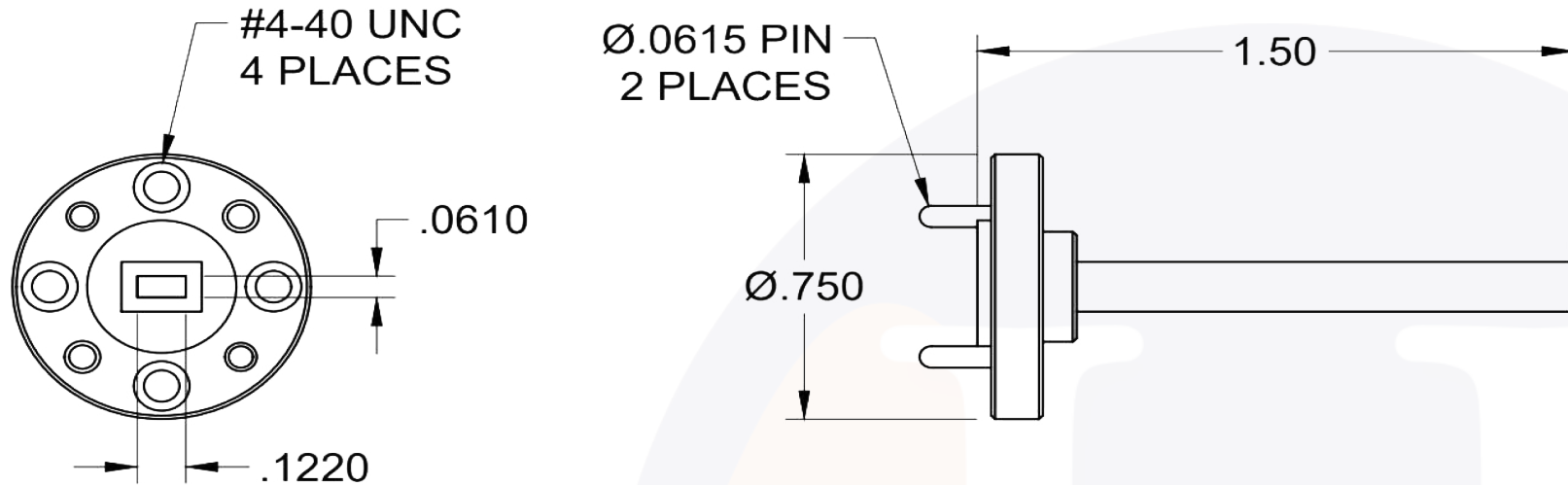

LTR	DESCRIPTION	DATE	APPR.	DRAWN BY: NS	
-	RELEASE	7/23	TC	REVIEWED BY: JS	APPROVED BY: TC
				THESE DRAWINGS AND SPECIFICATIONS ARE THE PROPERTY OF HASCO COMPONENTS AND SHALL NOT BE REPRODUCED, COPIED NOR USED - IN WHOLE OR IN PART - AS THE BASIS FOR THE MANUFACTURE OR SALE OF OTHER ITEMS WITHOUT THE EXPRESS, WRITTEN PERMISSION OF HASCO COMPONENTS.	
THIS DRAWING IS A CONTROLLED DOCUMENT					



5214 Bonsai Street • Moorpark, CA 93021
 (888) 498-3242 • sales@hasco-inc.com
www.hasco-inc.com

MATERIALS: SEE DATA SHEET	CAGE CODE: 0T8L4	SCALE: N/A	SIZE: A
FINISHES: SEE DATA SHEET	PART NO./DRAWING NO. HWLPT12-03-ER		REV: -